



Product flyer ZSM

Center hole grinding machine

ZAMAG



ZSM-M6-1000-SP150

with precision chuck \varnothing 150mm



swiss technology

One machine - Many advantages

Highest precision:

The machine achieves a concentricity accuracy of 0.001mm

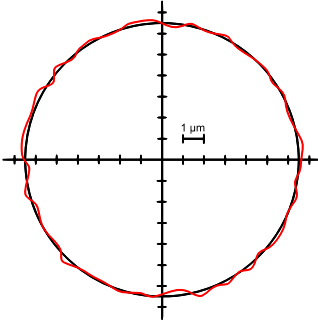

You have the workpiece - We have the suitable machine:

Thanks to a lot of equipment possibilities the machine can be adapted exactly to your requirements and workpieces

Swiss quality:

- Stable cast iron machine base (stress-free)
- Carriage with roller guides

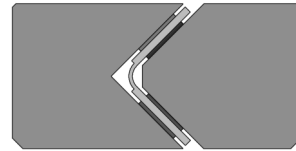

Clamping of the workpieces in the chuck:

With the help of the three adjustable quills even workpieces with an inaccurate surface can be clamped and aligned

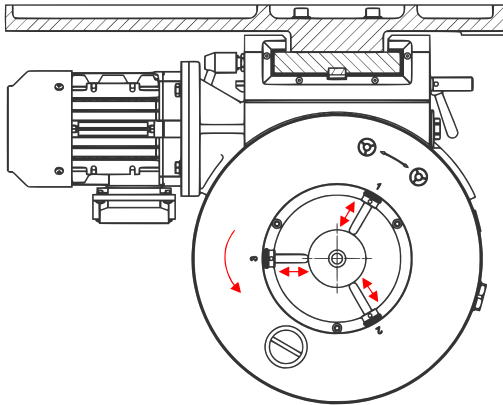

Swivelling grinding head:

With the swivelling head the grinding angle can be adjusted between 0° and 90°

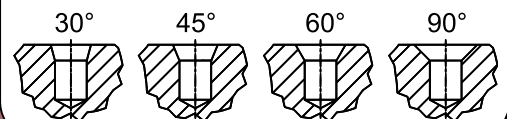

With a lot of experience to the optimal result:

Grinding principle:

1. rotary movement of the grinding wheel
2. stroke movement of the grinding wheel
3. rotating workpiece

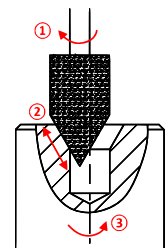

Result:

A cross hatch pattern with oil pockets that provides optimum oil retention in the center holes

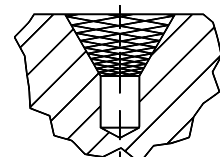

ZELLER AUTOMATIK AG

Bernstrasse 52

CH-4923 Wynau

+41 62 926 60 50

+41 62 926 60 59

mitracon@zamag.ch

www.zamag.ch